



element14

EN - For pricing and availability in your local country please visit one of the below links:

DE - Informationen zu Preisen und Verfügbarkeit in Ihrem Land erhalten Sie über die unten aufgeführten Links:

FR - Pour connaître les tarifs et la disponibilité dans votre pays, cliquez sur l'un des liens suivants:

[LM2591HVS-3.3/NOPB](#)

[LM2591HVT-ADJ/NOPB](#)

EN

This Datasheet is presented by
the manufacturer

DE

Dieses Datenblatt wird vom
Hersteller bereitgestellt

FR

Cette fiche technique est
présentée par le fabricant

LM2591HV SIMPLE SWITCHER® Power Converter 150 kHz 1A Step-Down Voltage Regulator

Check for Samples: [LM2591HV](#)

FEATURES

- 3.3V, 5V, and Adjustable Output Versions
- Adjustable Version Output Voltage Range, 1.2V to 57V $\pm 4\%$ Max Over Line and Load Conditions
- Specified 1A Output Load Current
- Available in 5-Pin Package
- Input Voltage Range Up to 60V
- 150 kHz Fixed Frequency Internal Oscillator
- On/Off Control
- Low Power Standby Mode, I_Q Typically 90 μ A
- High Efficiency
- Thermal Shutdown and Current Limit Protection

APPLICATIONS

- Simple High-Efficiency Step-Down (Buck) Regulator
- Efficient Pre-Regulator for Linear Regulators
- On-Card Switching Regulators
- Positive to Negative Converter

DESCRIPTION

The LM2591HV series of regulators are monolithic integrated circuits that provide all the active functions for a step-down (buck) switching regulator, capable of driving a 1A load with excellent line and load regulation. These devices are available in fixed output voltages of 3.3V, 5V, and an adjustable output version.

This series of switching regulators is similar to the LM2590HV, but without some of the supervisory and performance features of the latter.

Requiring a minimum number of external components, these regulators are simple to use and include internal frequency compensation†, improved line and load specifications and a fixed-frequency oscillator.

The LM2591HV operates at a switching frequency of 150 kHz thus allowing smaller sized filter components than what would be needed with lower frequency switching regulators. Available in a standard 5-lead package with several different lead bend options, and a 5-lead Surface mount package.

Other features include a specified $\pm 4\%$ tolerance on output voltage under all conditions of input voltage and output load conditions, and $\pm 15\%$ on the oscillator frequency. External shutdown is included, featuring typically 90 μ A standby current. Self protection features include a two stage current limit for the output switch and an over temperature shutdown for complete protection under fault conditions.

† Patent Number 5,382,918.

Typical Application

(Fixed Output Voltage Versions)

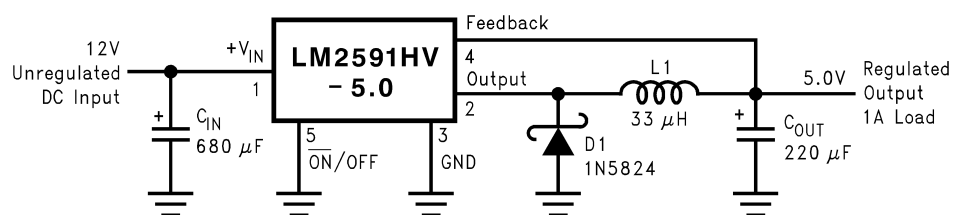
Figure 1.

Please be aware that an important notice concerning availability, standard warranty, and use in critical applications of Texas Instruments semiconductor products and disclaimers thereto appears at the end of this data sheet.

SIMPLE SWITCHER is a registered trademark of Texas Instruments.
All other trademarks are the property of their respective owners.



These devices have limited built-in ESD protection. The leads should be shorted together or the device placed in conductive foam during storage or handling to prevent electrostatic damage to the MOS gates.

ABSOLUTE MAXIMUM RATINGS ⁽¹⁾⁽²⁾

Maximum Supply Voltage (V_{IN})		63V	
ON/OFF Pin Voltage		$-0.3 \leq V \leq +25V$	
Feedback Pin Voltage		$-0.3 \leq V \leq +25V$	
Output Voltage to Ground	(Steady State)	-1V	
Power Dissipation		Internally limited	
Storage Temperature Range		$-65^{\circ}C$ to $+150^{\circ}C$	
ESD Susceptibility	Human Body Model ⁽³⁾	2 kV	
Lead Temperature	KTT Package	Vapor Phase (60 sec.)	$+215^{\circ}C$
		Infrared (10 sec.)	$+245^{\circ}C$
	NDH Package (Soldering, 10 sec.)	$+260^{\circ}C$	
Maximum Junction Temperature		$+150^{\circ}C$	

- (1) Absolute Maximum Ratings indicate limits beyond which damage to the device may occur. Operating Ratings indicate conditions for which the device is intended to be functional, but do not ensure specific performance limits. For ensured specifications and test conditions, see [Electrical Characteristics](#).
- (2) If Military/Aerospace specified devices are required, please contact the TI Sales Office/ Distributors for availability and specifications.
- (3) The human body model is a 100 pF capacitor discharged through a 1.5k resistor into each pin.

OPERATING CONDITIONS

Temperature Range	$-40^{\circ}C \leq T_J \leq +125^{\circ}C$
Supply Voltage	4.5V to 60V

ELECTRICAL CHARACTERISTICS LM2591HV-3.3

Specifications with standard type face are for $T_J = 25^{\circ}C$, and those with **boldface type** apply over **full Operating Temperature Range**.

Symbol	Parameter	Conditions	LM2591HV-3.3		Units (Limits)
			Typ ⁽¹⁾	Limit ⁽²⁾	
SYSTEM PARAMETERS Test Circuit Test Circuit and Layout Guidelines ⁽³⁾					
V_{OUT}	Output Voltage	$4.75V \leq V_{IN} \leq 60V$, $0.2A \leq I_{LOAD} \leq 1A$	3.3	3.168/ 3.135 3.432/ 3.465	V V(min) V(max)
η	Efficiency	$V_{IN} = 12V$, $I_{LOAD} = 1A$	77		

- (1) Typical numbers are at $25^{\circ}C$ and represent the most likely norm.
- (2) All limits ensured at room temperature (standard type face) and at **temperature extremes (bold type face)**. All room temperature limits are 100% production tested. All limits at **temperature extremes** are ensured via correlation using standard Statistical Quality Control (SQC) methods. All limits are used to calculate Average Outgoing Quality Level (AOQL).
- (3) External components such as the catch diode, inductor, input and output capacitors can affect switching regulator system performance. When the LM2591HV is used as shown in [Test Circuit and Layout Guidelines](#) test circuit, system performance will be as shown in [Electrical Characteristics](#).

ELECTRICAL CHARACTERISTICS LM2591HV-5.0

Specifications with standard type face are for $T_J = 25^\circ\text{C}$, and those with **boldface type** apply over **full Operating Temperature Range**.

Symbol	Parameter	Conditions	LM2591HV-5.0		Units (Limits)
			Typ ⁽¹⁾	Limit ⁽²⁾	
SYSTEM PARAMETERS Test Circuit Test Circuit and Layout Guidelines ⁽³⁾					
V_{OUT}	Output Voltage	$7\text{V} \leq V_{IN} \leq 60\text{V}$, $0.2\text{A} \leq I_{LOAD} \leq 1\text{A}$	5	4.800/ 4.750 5.200/ 5.250	V V(min) V(max)
η	Efficiency	$V_{IN} = 12\text{V}$, $I_{LOAD} = 1\text{A}$	82		%

- (1) Typical numbers are at 25°C and represent the most likely norm.
- (2) All limits ensured at room temperature (standard type face) and at **temperature extremes (bold type face)**. All room temperature limits are 100% production tested. All limits at **temperature extremes** are ensured via correlation using standard Statistical Quality Control (SQC) methods. All limits are used to calculate Average Outgoing Quality Level (AOQL).
- (3) External components such as the catch diode, inductor, input and output capacitors can affect switching regulator system performance. When the LM2591HV is used as shown in [Test Circuit and Layout Guidelines](#) test circuit, system performance will be as shown in [Electrical Characteristics](#).

ELECTRICAL CHARACTERISTICS LM2591HV-ADJ

Specifications with standard type face are for $T_J = 25^\circ\text{C}$, and those with **boldface type** apply over **full Operating Temperature Range**.

Symbol	Parameter	Conditions	LM2591HV-ADJ		Units (Limits)
			Typ ⁽¹⁾	Limit ⁽²⁾	
SYSTEM PARAMETERS Test Circuit Test Circuit and Layout Guidelines ⁽³⁾					
V_{FB}	Feedback Voltage	$4.5\text{V} \leq V_{IN} \leq 60\text{V}$, $0.2\text{A} \leq I_{LOAD} \leq 1\text{A}$ V_{OUT} programmed for 3V. Circuit of Test Circuit and Layout Guidelines .	1.230	1.193/ 1.180 1.267/ 1.280	V V(min) V(max)
η	Efficiency	$V_{IN} = 12\text{V}$, $V_{OUT} = 3\text{V}$, $I_{LOAD} = 1\text{A}$	76		%

- (1) Typical numbers are at 25°C and represent the most likely norm.
- (2) All limits ensured at room temperature (standard type face) and at **temperature extremes (bold type face)**. All room temperature limits are 100% production tested. All limits at **temperature extremes** are ensured via correlation using standard Statistical Quality Control (SQC) methods. All limits are used to calculate Average Outgoing Quality Level (AOQL).
- (3) External components such as the catch diode, inductor, input and output capacitors can affect switching regulator system performance. When the LM2591HV is used as shown in [Test Circuit and Layout Guidelines](#) test circuit, system performance will be as shown in [Electrical Characteristics](#).

ELECTRICAL CHARACTERISTICS ALL OUTPUT VOLTAGE VERSIONS

Specifications with standard type face are for $T_J = 25^\circ\text{C}$, and those with **boldface type** apply over **full Operating Temperature Range**. Unless otherwise specified, $V_{IN} = 12\text{V}$ for the 3.3V, 5V, and Adjustable version. $I_{LOAD} = 500\text{ mA}$

Symbol	Parameter	Conditions	LM2591HV-XX		Units (Limits)
			Typ ⁽¹⁾	Limit ⁽²⁾	
DEVICE PARAMETERS					
I_b	Feedback Bias Current	Adjustable Version Only, $V_{FB} = 1.3\text{V}$	10	50/ 100	nA nA (max)
f_O	Oscillator Frequency	See ⁽³⁾	150	127/ 110 173/ 173	kHz kHz(min) kHz(max)
V_{SAT}	Saturation Voltage	$I_{OUT} = 1\text{A}$ ⁽⁴⁾⁽⁵⁾	0.95	1.2/ 1.3	V V(max)

- (1) Typical numbers are at 25°C and represent the most likely norm.
- (2) All limits ensured at room temperature (standard type face) and at **temperature extremes (bold type face)**. All room temperature limits are 100% production tested. All limits at **temperature extremes** are ensured via correlation using standard Statistical Quality Control (SQC) methods. All limits are used to calculate Average Outgoing Quality Level (AOQL).
- (3) The switching frequency is reduced when the second stage current limit is activated. The amount of reduction is determined by the severity of current overload.
- (4) No diode, inductor or capacitor connected to output pin.
- (5) Feedback pin removed from output and connected to 0V to force the output transistor switch ON.

ELECTRICAL CHARACTERISTICS ALL OUTPUT VOLTAGE VERSIONS (continued)

Specifications with standard type face are for $T_J = 25^\circ\text{C}$, and those with **boldface type** apply over **full Operating Temperature Range**. Unless otherwise specified, $V_{IN} = 12\text{V}$ for the 3.3V, 5V, and Adjustable version. $I_{LOAD} = 500\text{ mA}$

Symbol	Parameter	Conditions	LM2591HV-XX		Units (Limits)
			Typ ⁽¹⁾	Limit ⁽²⁾	
DC	Max Duty Cycle (ON) Min Duty Cycle (OFF)	See ⁽⁵⁾⁽⁶⁾	100 0		%
I_{CLIM}	Switch current Limit	Peak Current, ⁽⁴⁾⁽⁵⁾	1.9	1.3/ 1.2 2.8/ 3.0	A A(min) A(max)
I_L	Output Leakage Current	Output = 0V Output = -1V ⁽⁴⁾⁽⁶⁾⁽⁷⁾	5	50 30	$\mu\text{A}(\text{max})$ mA mA(max)
I_Q	Operating Quiescent Current	$\overline{\text{SD}}$ /SS Pin Open ⁽⁶⁾	5	10	mA mA(max)
I_{STBY}	Standby Quiescent Current	$\overline{\text{SD}}$ /SS pin = 0V ⁽⁷⁾	90	200/ 250	μA $\mu\text{A}(\text{max})$
θ_{JC} θ_{JA} θ_{JA} θ_{JA} θ_{JA}	Thermal Resistance	TO220 or TO263 Package, Junction to Case TO220 Package, Junction to Ambient ⁽⁸⁾ TO263 Package, Junction to Ambient ⁽⁹⁾ TO263 Package, Junction to Ambient ⁽¹⁰⁾ TO263 Package, Junction to Ambient ⁽¹¹⁾	2 50 50 30 20		$^\circ\text{C}/\text{W}$ $^\circ\text{C}/\text{W}$ $^\circ\text{C}/\text{W}$ $^\circ\text{C}/\text{W}$ $^\circ\text{C}/\text{W}$
ON/OFF CONTROL Test Circuit Test Circuit and Layout Guidelines					
V_{IH} V_{IL}	$\overline{\text{ON}}$ /OFF Pin Logic Input Threshold Voltage	Low (Regulator ON) High (Regulator OFF)	1.3	0.6 2.0	V V(max) V(min)
I_H	$\overline{\text{ON}}$ /OFF Pin Input Current	$V_{LOGIC} = 2.5\text{V}$ (Regulator OFF)	5	15	μA $\mu\text{A}(\text{max})$
I_L		$V_{LOGIC} = 0.5\text{V}$ (Regulator ON)	0.02	5	μA $\mu\text{A}(\text{max})$

(6) Feedback pin removed from output and connected to 12V for the 3.3V, 5V, and the ADJ. version to force the output transistor switch OFF.

(7) $V_{IN} = 60\text{V}$.

(8) Junction to ambient thermal resistance (no external heat sink) for the package mounted TO-220 package mounted vertically, with the leads soldered to a printed circuit board with (1 oz.) copper area of approximately 1 in².

(9) Junction to ambient thermal resistance with the TO-263 package tab soldered to a single sided printed circuit board with 0.5 in² of (1 oz.) copper area.

(10) Junction to ambient thermal resistance with the TO-263 package tab soldered to a single sided printed circuit board with 2.5 in² of (1 oz.) copper area.

(11) Junction to ambient thermal resistance with the TO-263 package tab soldered to a double sided printed circuit board with 3 in² of (1 oz.) copper area on the LM2591HVS side of the board, and approximately 16 in² of copper on the other side of the p-c board. See

[APPLICATION INFORMATION](#) in this data sheet and the thermal model in **Switchers Made Simple** available at http://www.ti.com/lscs/ti/analog/powermanagement/power_portal.page.

TYPICAL PERFORMANCE CHARACTERISTICS

(Circuit of [Test Circuit](#) and [Layout Guidelines](#))

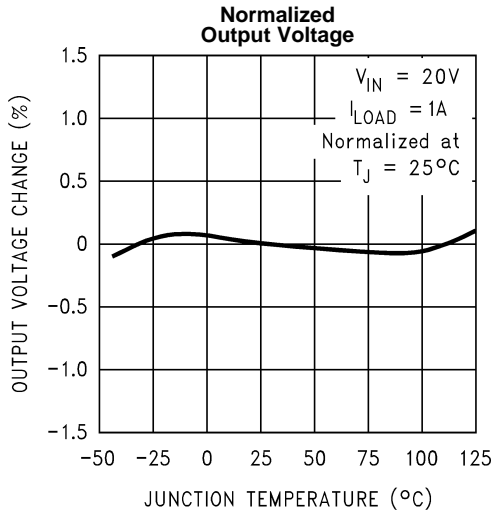

Figure 2.

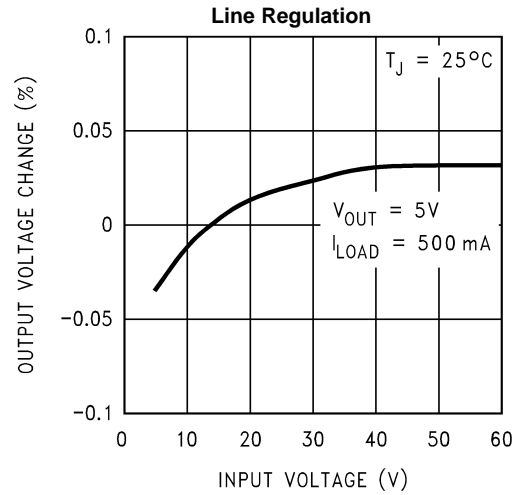

Figure 3.

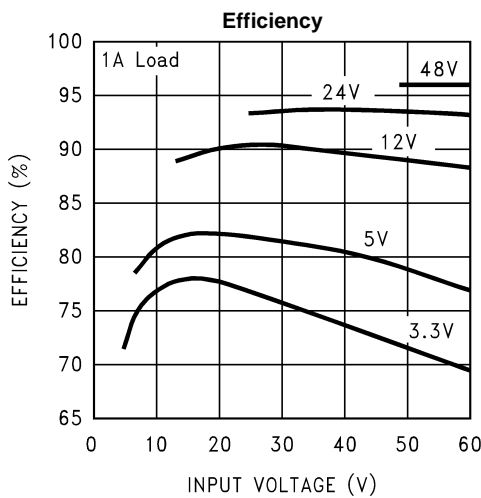

Figure 4.

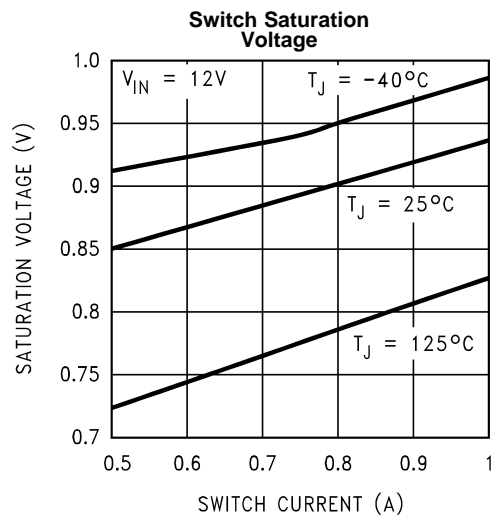

Figure 5.

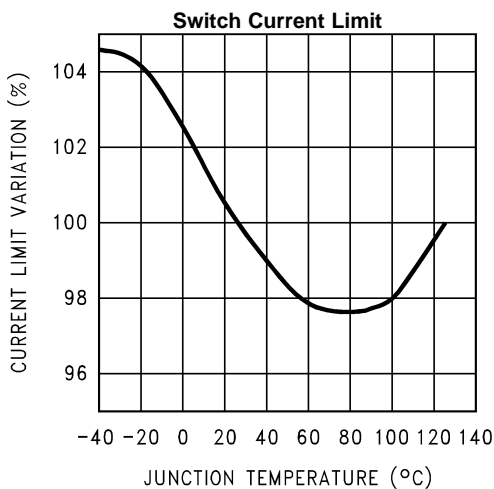

Figure 6.

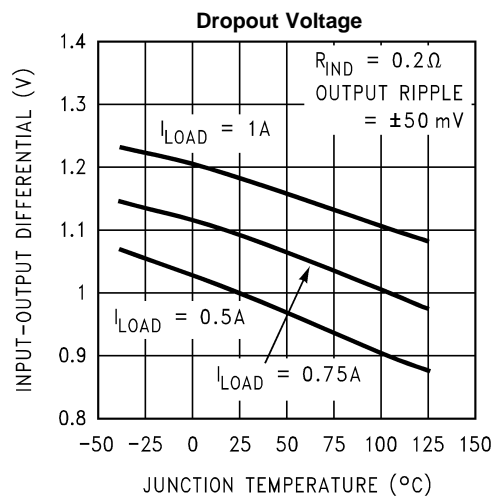

Figure 7.

TYPICAL PERFORMANCE CHARACTERISTICS (continued)

(Circuit of [Test Circuit and Layout Guidelines](#))

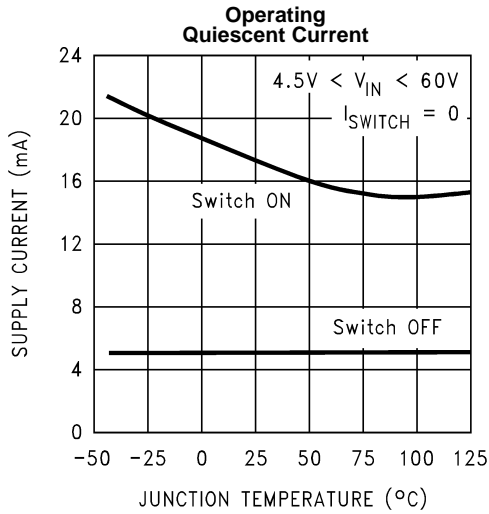

Figure 8.

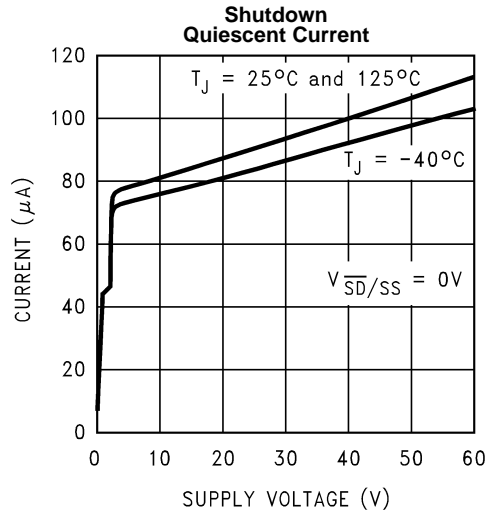

Figure 9.

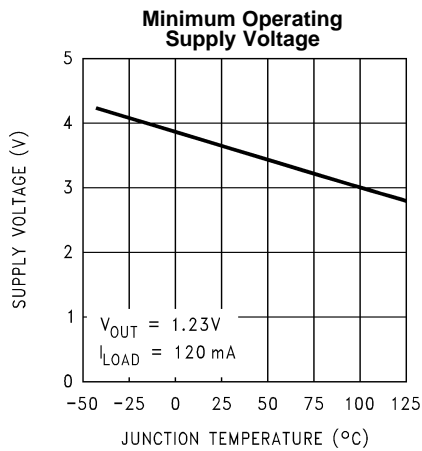

Figure 10.

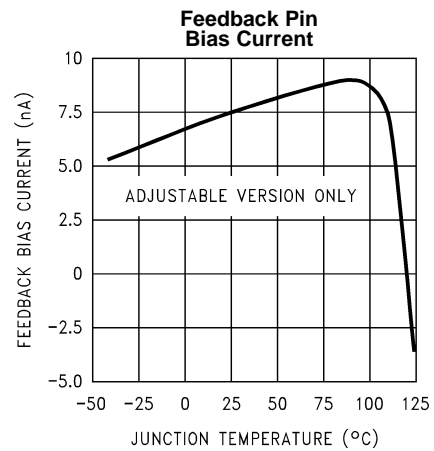

Figure 11.

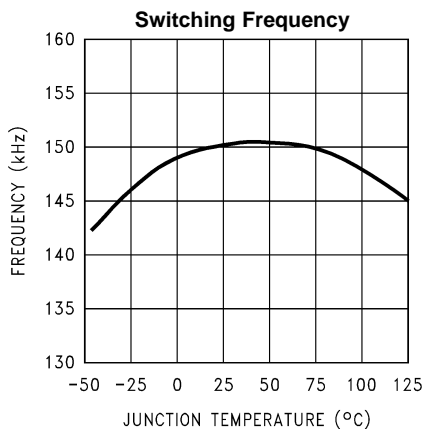

Figure 12.

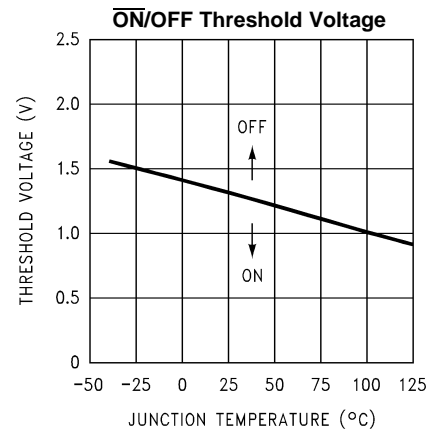

Figure 13.

TYPICAL PERFORMANCE CHARACTERISTICS (continued)

(Circuit of Test Circuit and Layout Guidelines)

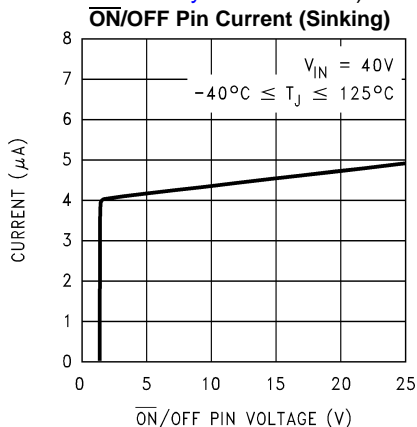

Figure 14.

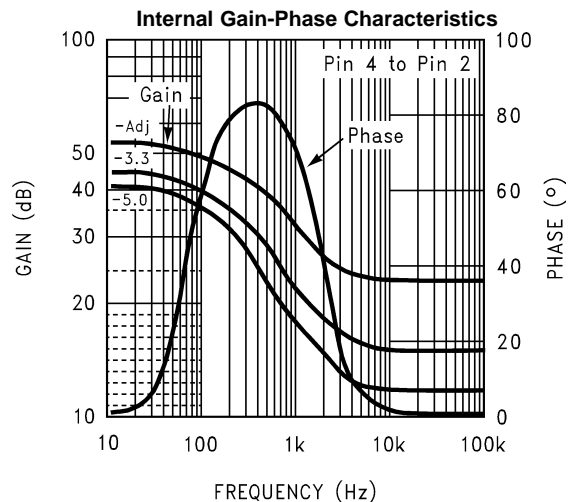
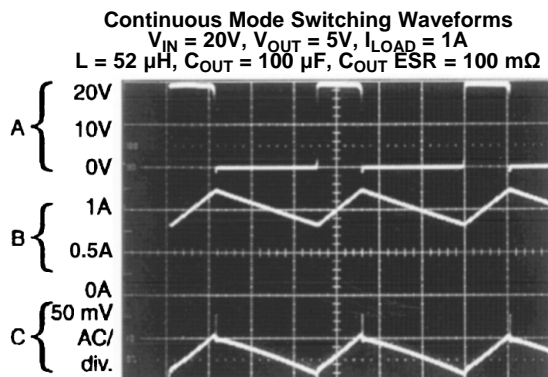
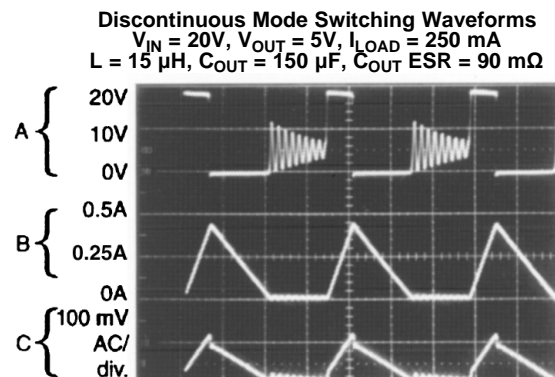

Figure 15.



A: Output Pin Voltage, 10V/div.
 B: Inductor Current 0.5A/div.
 C: Output Ripple Voltage, 50 mV/div.

Figure 16. Horizontal Time Base: 2 µs/div.



A: Output Pin Voltage, 10V/div.
 B: Inductor Current 0.25A/div.
 C: Output Ripple Voltage, 100 mV/div.

Figure 17. Horizontal Time Base: 2 µs/div.

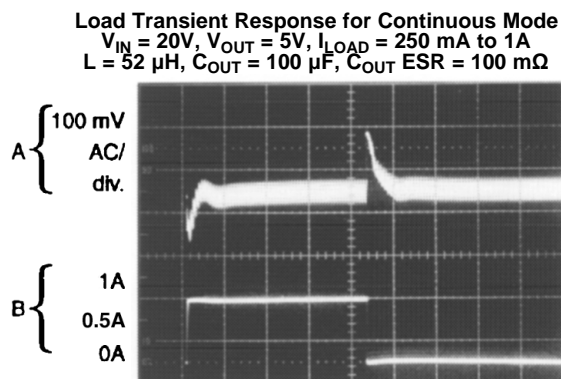

A: Output Voltage, 100 mV/div. (AC)
 B: 250 mA to 1A Load Pulse

Figure 18. Horizontal Time Base: 50 µs/div.

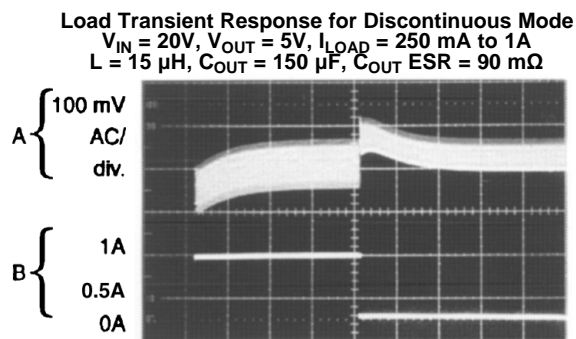

A: Output Voltage, 100 mV/div. (AC)
 B: 250 mA to 1A Load Pulse

Figure 19. Horizontal Time Base: 200 µs/div.

CONNECTION DIAGRAMS

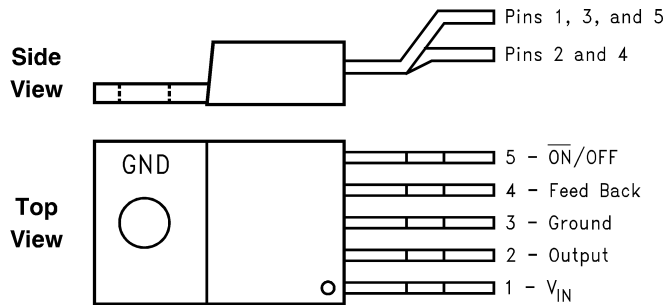

Figure 20. Bent and Staggered Leads, Through Hole Package
5-Lead TO-220 (NDH)
See Package Number NDH0005D

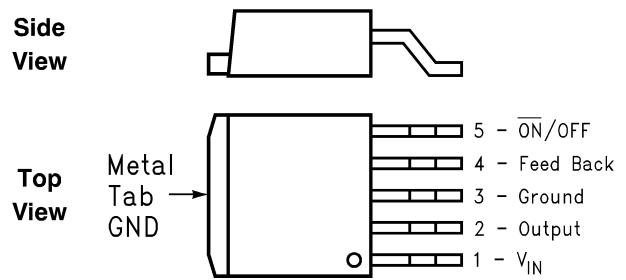
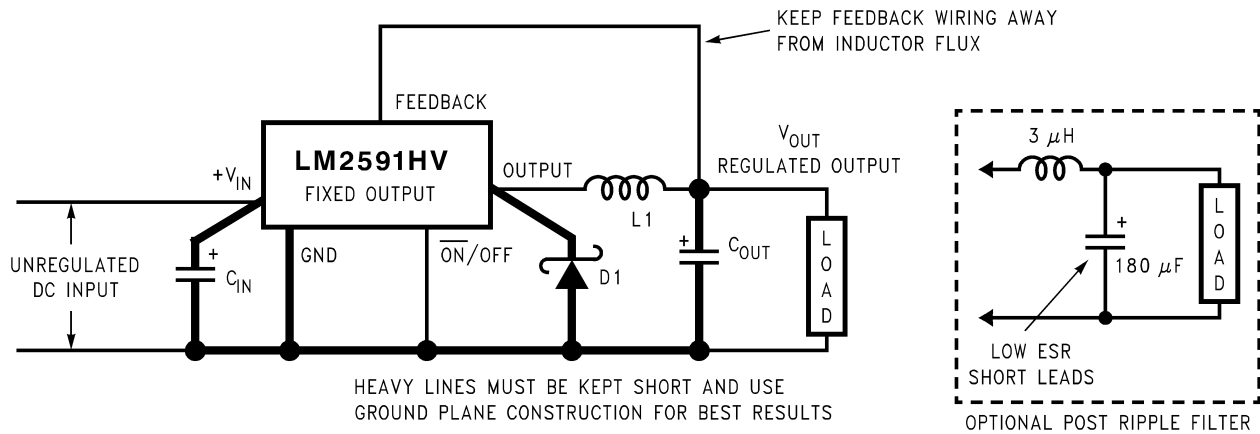

Figure 21. Surface Mount Package
5-Lead TO-263 (KTT)
See Package Number KTT0005B LM2591HV 7

Test Circuit and Layout Guidelines



Component Values shown are for $V_{\text{IN}} = 15\text{V}$,
 $V_{\text{OUT}} = 5\text{V}$, $I_{\text{LOAD}} = 1\text{A}$.
 C_{IN} — 470 μF , 50V, Aluminum Electrolytic Nichicon "PM Series"
 C_{OUT} — 220 μF , 25V Aluminum Electrolytic, Nichicon "PM Series"
 $D1$ — 2A, 60V Schottky Rectifier, 21DQ06 (International Rectifier)
 $L1$ — 68 H, See [INDUCTOR SELECTION PROCEDURE](#)

Figure 22. Fixed Output Voltage Versions

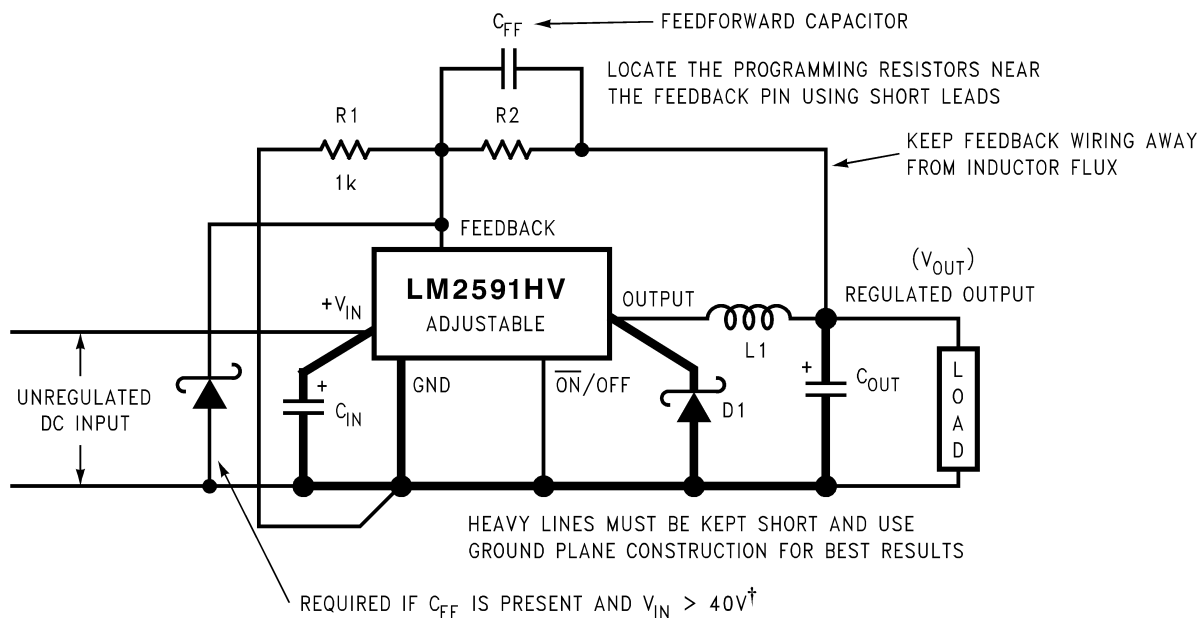

Select R_1 to be approximately 1 k Ω , use a 1% resistor for best stability.

Component Values shown are for $V_{IN} = 20V$,

$V_{OUT} = 10V$, $I_{LOAD} = 1A$.

C_{IN} : — 470 μF , 35V, Aluminum Electrolytic Nichicon "PM Series"

C_{OUT} : — 220 μF , 35V Aluminum Electrolytic, Nichicon "PM Series"

D1 — 2A, 60V Schottky Rectifier, 21DQ06 (International Rectifier)

See [INDUCTOR SELECTION PROCEDURE](#) L1 — 100 μH ,

R_1 — 1 k Ω , 1%

R_2 — 7.15k, 1%

C_{FF} — 3.3 nF

Typical Values

C_{SS} —0.1 μF

C_{DELAY} —0.1 μF

$R_{PULL UP}$ — 4.7k (use 22k if V_{OUT} is $\geq 45V$)

† Small signal Schottky diode to prevent damage to feedback pin by negative spike when output is shorted (C_{FF} not being able to discharge immediately will drag feedback pin below ground). Required if $V_{IN} > 40V$

Figure 23. Adjustable Output Voltage Versions

BLOCK DIAGRAM

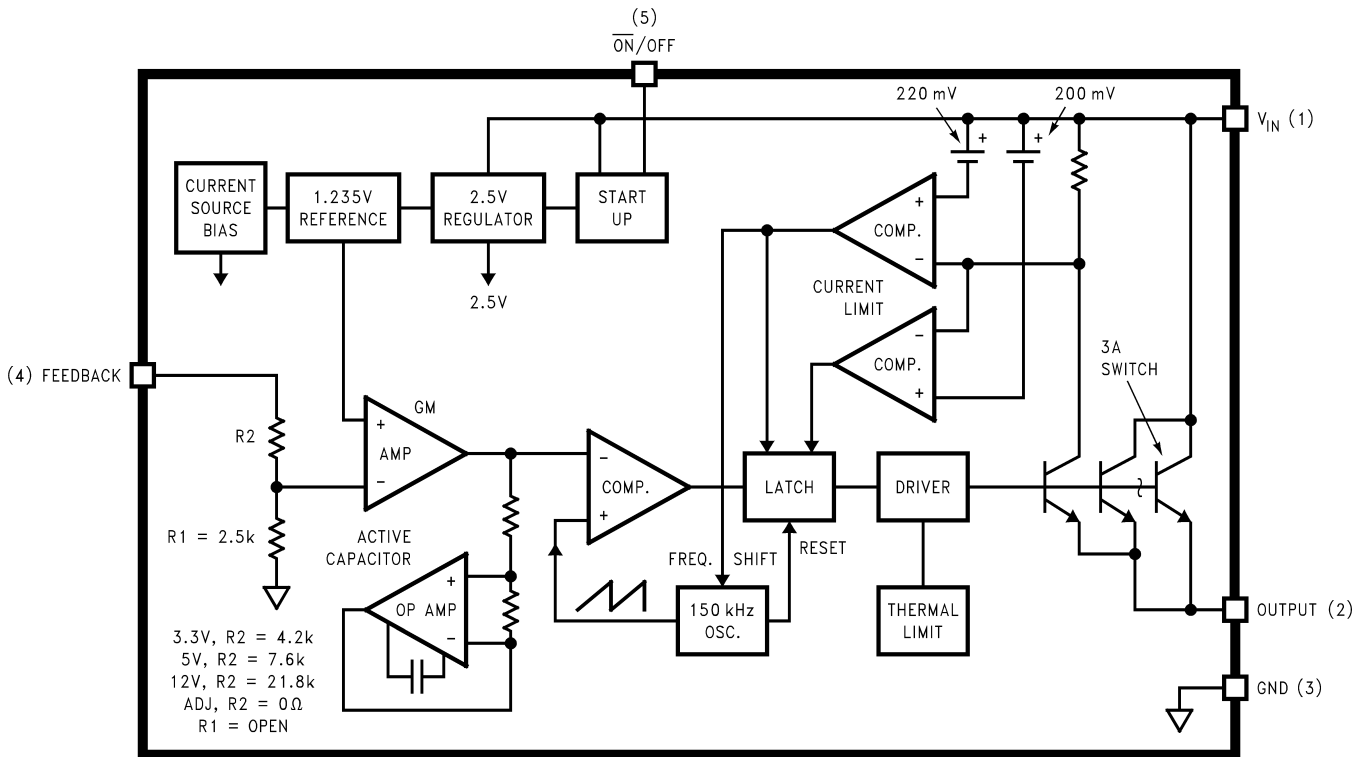

Figure 24.

PIN FUNCTIONS

+ V_{IN} (Pin 1) This is the positive input supply for the IC switching regulator. A suitable input bypass capacitor must be present at this pin to minimize voltage transients and to supply the switching currents needed by the regulator.

Output (Pin 2) Internal switch. The voltage at this pin switches between approximately $(+V_{IN} - V_{SAT})$ and approximately $-0.5V$, with a duty cycle of V_{OUT}/V_{IN} .

Ground (Pin 3) Circuit ground.

Feedback (Pin 4) Senses the regulated output voltage to complete the feedback loop. This pin is directly connected to the Output for the fixed voltage versions, but is set to 1.23V by means of a resistive divider from the output for the Adjustable version. If a feedforward capacitor is used (Adjustable version), then a negative voltage spike is generated on this pin whenever the output is shorted. This happens because the feedforward capacitor cannot discharge fast enough, and since one end of it is dragged to Ground, the other end goes momentarily negative. To prevent the energy rating of this pin from being exceeded, a small-signal Schottky diode to Ground is recommended for DC input voltages above 40V whenever a feedforward capacitor is present (See [Test Circuit and Layout Guidelines](#)). Feedforward capacitor values larger than 0.1 μF are not recommended for the same reason, whatever be the DC input voltage.

ON/OFF (Pin 5) The regulator is in shutdown mode, drawing about 90 μA , when this pin is driven to a high level ($\geq 2.0V$), and is in normal operation when this Pin is left floating or driven to a low level ($\leq 0.6V$). The typical value of the threshold is 1.3V and the voltage on this pin must not exceed 25V.

Inductor Value Selection Guides

(For Continuous Mode Operation)

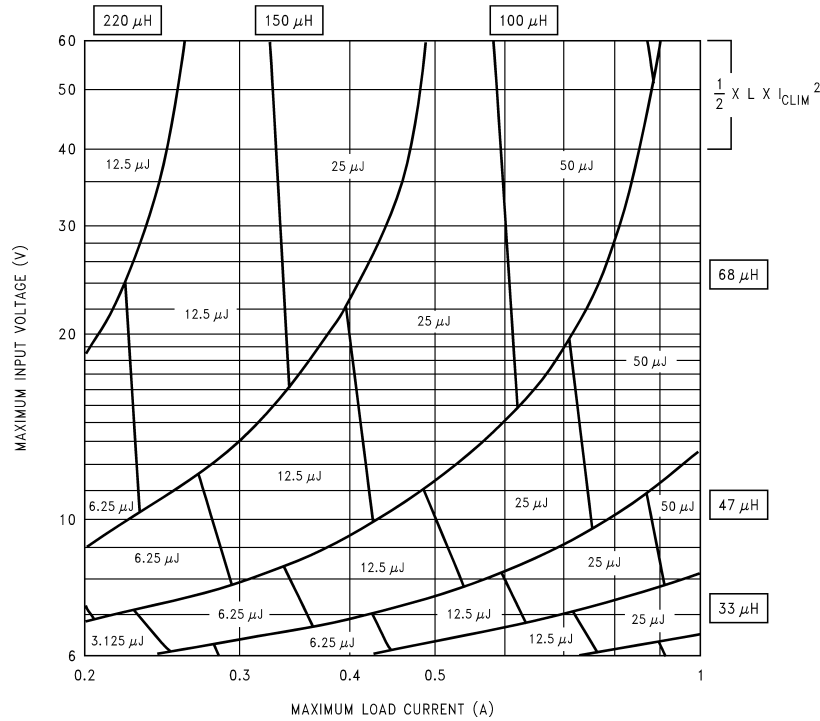

Figure 25. LM2591HV-3.3

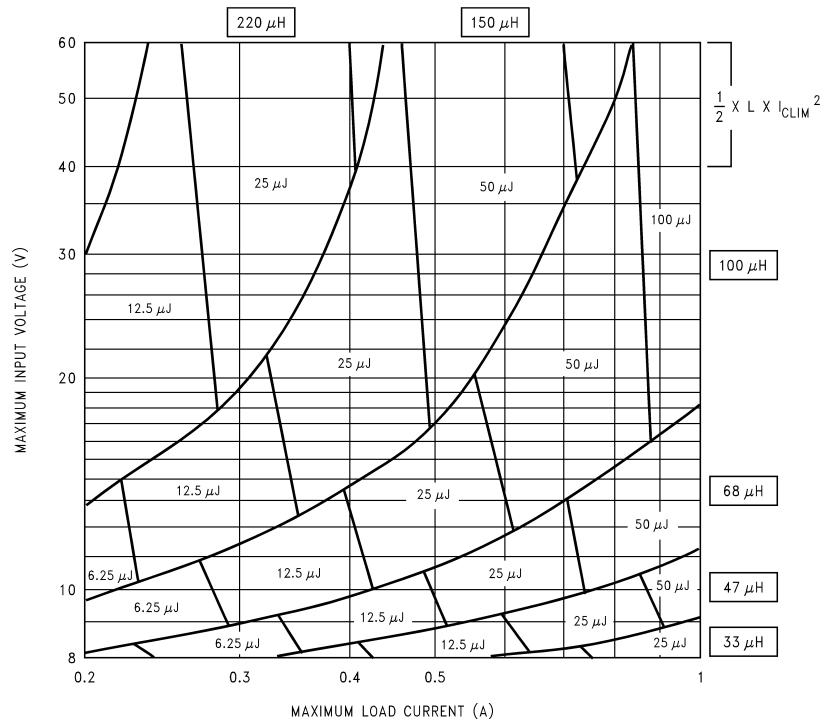

Figure 26. LM2591HV-5.0

(For Continuous Mode Operation)

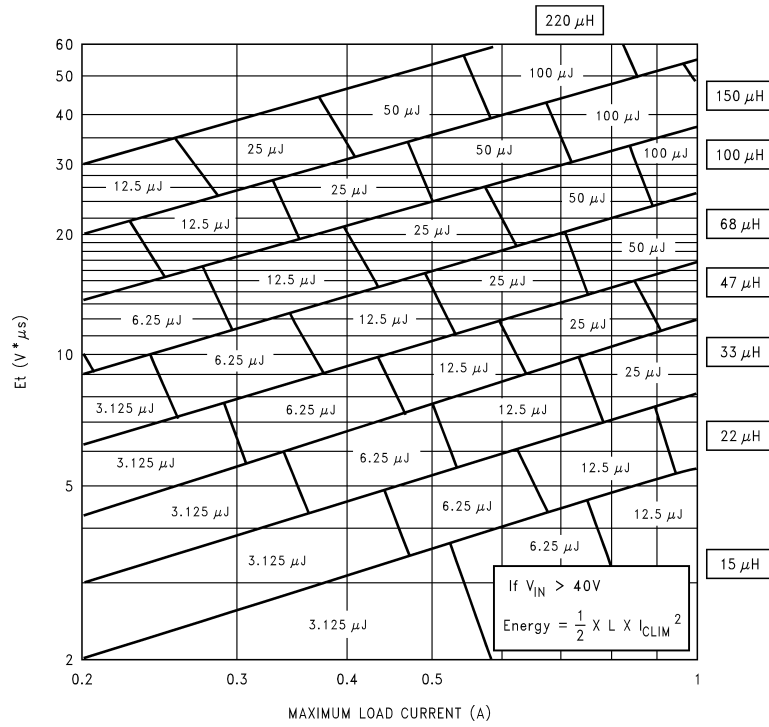

Figure 27. LM2591HV-ADJ

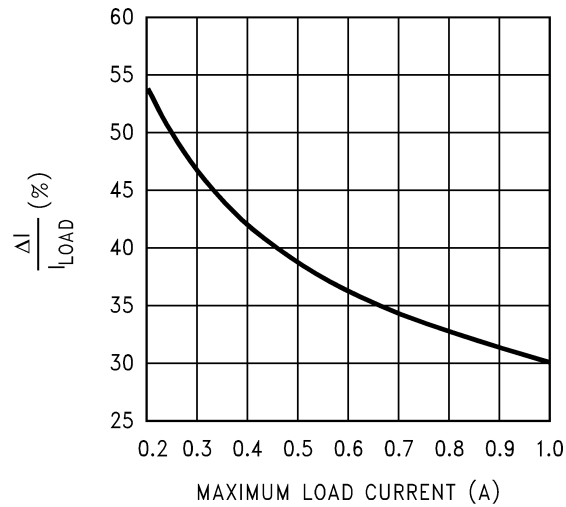

Figure 28. Current Ripple Ratio

(For Continuous Mode Operation)

Table 1. Contact Information for Suggested Inductor Manufacturers

Coilcraft Inc.	Phone	(USA): 1-800-322-2645
	Web Address	http://www.coilcraft.com
Coilcraft Inc., Europe	Phone	(UK): 1-236-730595
	Web Address	http://www.coilcraft-europe.com
Pulse Engineering Inc.	Phone	(USA): 1-858-674-8100
	Web Address	http://www.pulseeng.com
Pulse Engineering Inc., Europe	Phone	(UK): 1-483-401700
	Web Address	http://www.pulseeng.com
Renco Electronics Inc.	Phone	(USA): 1-321-637-1000
	Web Address	http://www.rencousa.com
Schott Corp.	Phone	(USA): 1-952-475-1173
	Web Address	http://www.shottcorp.com
Cooper Electronic Tech. (Coiltronics)	Phone	(USA): 1-888-414-2645
	Web Address	http://www.cooperet.com
TDK	Phone	(USA): 1-847-803-6100
	Web Address	http://www.componet.tdk.com

APPLICATION INFORMATION

INDUCTOR SELECTION PROCEDURE

Application Note AN-1197 [SNVA038](#) titled "Selecting Inductors for Buck Converters" provides detailed information on this topic. For a quick-start the designer may refer to the nomographs provided in [Figure 25](#) to [Figure 27](#). To widen the choice of the Designer to a more general selection of available inductors, the nomographs provide the required inductance and also the energy in the core expressed in microjoules (μJ), as an alternative to just prescribing custom parts. The following points need to be highlighted:

1. The Energy values shown on the nomographs apply to steady operation at the corresponding x-coordinate (rated maximum load current). However under start-up, without soft-start, or a short-circuit on the output, the current in the inductor will momentarily/repetitively hit the current limit I_{CLIM} of the device, and this current could be much higher than the rated load, I_{LOAD} . This represents an overload situation, and can cause the Inductor to saturate (if it has been designed only to handle the energy of steady operation). However most types of core structures used for such applications have a large inherent air gap (for example powdered iron types or ferrite rod inductors), and so the inductance does not fall off too sharply under an overload. The device is usually able to protect itself by not allowing the current to ever exceed I_{CLIM} . But if the DC input voltage to the regulator is over 40V, the current can slew up so fast under core saturation, that the device may not be able to act fast enough to restrict the current. The current can then rise without limit till destruction of the device takes place. *Therefore to ensure reliability, it is recommended, that if the DC Input Voltage exceeds 40V, the inductor must ALWAYS be sized to handle an instantaneous current equal to I_{CLIM} without saturating, irrespective of the type of core structure/material.*
2. The Energy under steady operation is:

$$e = \frac{1}{2} \times L \times I_{\text{PEAK}}^2 \quad \mu\text{J}$$

where

- L is in μH
- I_{PEAK} is the peak of the inductor current waveform with the regulator delivering I_{LOAD} . These are the energy values shown in the nomographs. See [Example 1](#). (1)

3. The Energy under overload is

$$e_{\text{CLIM}} = \frac{1}{2} \times L \times I_{\text{CLIM}}^2 \quad \mu\text{J} \tag{2}$$

If $V_{\text{IN}} > 40\text{V}$, the inductor should be sized to handle e_{CLIM} instead of the steady energy values. The worst case I_{CLIM} for the LM2591HV is 3A. The Energy rating depends on the Inductance. See [Example 2](#).

4. The nomographs were generated by allowing a greater amount of percentage current ripple in the Inductor as the maximum rated load decreases (see [Figure 28](#)). This was done to permit the use of smaller inductors at light loads. However [Figure 28](#) shows only the 'median' value of the current ripple. In reality there may be a great spread around this because the nomographs approximate the exact calculated inductance to standard available values. It is a good idea to refer to AN-1197 [SNVA038](#) for detailed calculations if a certain maximum inductor current ripple is required for various possible reasons. Also consider the rather wide tolerance on the nominal inductance of commercial inductors.
5. [Figure 27](#) shows the inductor selection curves for the Adjustable version. The y-axis is 'Et', in $\text{V}\mu\text{secs}$. It is the applied volts across the inductor during the ON time of the switch ($V_{\text{IN}} - V_{\text{SAT}} - V_{\text{OUT}}$) multiplied by the time for which the switch is on in μsecs . See [Example 3](#).

Example 1: ($V_{\text{IN}} \leq 40\text{V}$) LM2591HV-5.0, $V_{\text{IN}} = 24\text{V}$, Output 5V @ 0.8A

1. A first pass inductor selection is based upon *Inductance and rated max load current*. We choose an inductor with the Inductance value indicated by the nomograph (see [Figure 26](#)) and a current rating equal to the maximum load current. We therefore quick-select a $100\mu\text{H}/0.8\text{A}$ inductor (designed for 150 kHz operation) for this application.
2. We should confirm that it is rated to handle 50 μJ (see [Figure 26](#)) by either estimating the peak current or by a detailed calculation as shown in AN-1197 [SNVA038](#), and also that the losses are acceptable.

Example 2: ($V_{IN} > 40V$) LM2591HV-5.0, $V_{IN} = 48V$, Output 5V @ 1A

1. A first pass inductor selection is based upon *Inductance and the switch current limit*. We choose an inductor with the Inductance value indicated by the nomograph ([Figure 26](#)) and a current rating equal to I_{CLIM} . We therefore quick-select a 100 μ H/3A inductor (designed for 150 kHz operation) for this application.

2. We should confirm that it is rated to handle e_{CLIM} by the procedure shown in AN-1197 [SNVA038](#) and that the losses are acceptable. Here e_{CLIM} is:

$$e_{CLIM} = \frac{1}{2} \times 100 \times 3^2 = 450 \mu J \quad (3)$$

Example 3: ($V_{IN} \leq 40V$) LM2591HV-ADJ, $V_{IN} = 20V$, Output 10V @ 1A

1. Since input voltage is less than 40V, a first pass inductor selection is based upon Inductance and rated max load current. We choose an inductor with the Inductance value indicated by the nomograph [Figure 27](#) and a current rating equal to the maximum load. But we first need to calculate Et for the given application. The Duty cycle is

$$D = \frac{V_{OUT} + V_D}{V_{IN} - V_{SAT} + V_D}$$

where

- V_D is the drop across the Catch Diode ($\approx 0.5V$ for a Schottky)
 - V_{SAT} the drop across the switch ($\approx 1.5V$)
- (4)

So

$$D = \frac{10 + 0.5}{20 - 1.5 + 0.5} = 0.55 \quad (5)$$

And the switch ON time is

$$t_{ON} = \frac{D}{f} \times 10^6 \mu s$$

where

- f is the switching frequency in Hz
- (6)

So

$$\begin{aligned} Et &= (V_{IN} - V_{SAT} - V_{OUT}) \times t_{ON} \\ &= (20 - 1.5 - 10) \times \frac{0.55}{150000} \times 10^6 V\mu\text{secs} \\ &= 31.3 V\mu\text{secs} \end{aligned} \quad (7)$$

Therefore, looking at [Figure 25](#) we quick-select a 100 μ H/1A inductor (designed for 150 kHz operation) for this application.

2. We should confirm that it is rated to handle 100 μ J (see [Figure 27](#)) by the procedure shown in AN-1197 [SNVA038](#) and that the losses are acceptable. (If the DC Input voltage had been greater than 40V we would need to consider e_{CLIM} as in Example 2 above).

Note that we have taken V_{SAT} as 1.5V which includes an estimated resistive drop across the inductor.

This completes the simplified inductor selection procedure. For more general applications and better optimization, the designer should refer to AN-1197 [SNVA038](#). [Table 1](#) provides helpful contact information on suggested Inductor manufacturers who may be able to recommend suitable parts, if the requirements are known.

FEEDFORWARD CAPACITOR

(Adjustable Output Voltage Version)

C_{FF} - A Feedforward Capacitor C_{FF} , shown across R2 in [Test Circuit and Layout Guidelines](#) is used when the output voltage is greater than 10V or when C_{OUT} has a very low ESR. This capacitor adds lead compensation to the feedback loop and increases the phase margin for better loop stability.

(Adjustable Output Voltage Version)

If the output voltage ripple is large (> 5% of the nominal output voltage), this ripple can be coupled to the feedback pin through the feedforward capacitor and cause the error comparator to trigger the error flag. In this situation, adding a resistor, R_{FF} , in series with the feedforward capacitor, approximately 3 times R_1 , will attenuate the ripple voltage at the feedback pin.

INPUT CAPACITOR

C_{IN} —A low ESR aluminum or tantalum bypass capacitor is needed between the input pin and ground pin. It must be located near the regulator using short leads. This capacitor prevents large voltage transients from appearing at the input, and provides the instantaneous current needed each time the switch turns on.

The important parameters for the Input capacitor are the voltage rating and the RMS current rating. Because of the relatively high RMS currents flowing in a buck regulator's input capacitor, this capacitor should be chosen for its RMS current rating rather than its capacitance or voltage ratings, although the capacitance value and voltage rating are directly related to the RMS current rating. The voltage rating of the capacitor and its RMS ripple current capability must never be exceeded.

OUTPUT CAPACITOR

C_{OUT} —An output capacitor is required to filter the output and provide regulator loop stability. Low impedance or low ESR Electrolytic or solid tantalum capacitors designed for switching regulator applications must be used. When selecting an output capacitor, the important capacitor parameters are; the 100 kHz Equivalent Series Resistance (ESR), the RMS ripple current rating, voltage rating, and capacitance value. For the output capacitor, the ESR value is the most important parameter. The ESR should generally not be less than 100 mΩ or there will be loop instability. If the ESR is too large, efficiency and output voltage ripple are effected. So ESR must be chosen carefully.

CATCH DIODE

Buck regulators require a diode to provide a return path for the inductor current when the switch turns off. This must be a fast diode and must be located close to the LM2591HV using short leads and short printed circuit traces.

Because of their very fast switching speed and low forward voltage drop, Schottky diodes provide the best performance, especially in low output voltage applications (5V and lower). Ultra-fast recovery, or High-Efficiency rectifiers are also a good choice, but some types with an abrupt turnoff characteristic may cause instability or EMI problems. Ultra-fast recovery diodes typically have reverse recovery times of 50 ns or less. The diode must be chosen for its average/RMS current rating and maximum voltage rating. The voltage rating of the diode must be greater than the DC input voltage (not the output voltage).

DELAYED STARTUP

The circuit in [Figure 29](#) uses the \overline{ON} /OFF pin to provide a time delay between the time the input voltage is applied and the time the output voltage comes up (only the circuitry pertaining to the delayed start up is shown). As the input voltage rises, the charging of capacitor C1 pulls the \overline{ON} /OFF pin high, keeping the regulator off. Once the input voltage reaches its final value and the capacitor stops charging, and resistor R_2 pulls the \overline{ON} /OFF pin low, thus allowing the circuit to start switching. Resistor R_1 is included to limit the maximum voltage applied to the \overline{ON} /OFF pin (maximum of 25V), reduces power supply noise sensitivity, and also limits the capacitor, C1, discharge current. When high input ripple voltage exists, avoid long delay time, because this ripple can be coupled into the \overline{ON} /OFF pin and cause problems.

This delayed startup feature is useful in situations where the input power source is limited in the amount of current it can deliver. It allows the input voltage to rise to a higher voltage before the regulator starts operating. Buck regulators require less input current at higher input voltages.

(Adjustable Output Voltage Version)

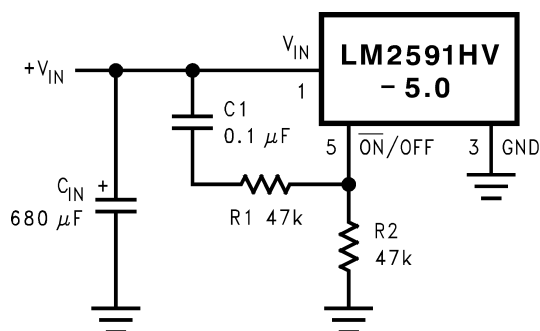

Figure 29. Delayed Startup

UNDERVOLTAGE LOCKOUT

Some applications require the regulator to remain off until the input voltage reaches a predetermined voltage. An undervoltage lockout feature applied to a buck regulator is shown in Figure 30, while Figure 31 and Figure 32 applies the same feature to an inverting circuit. The circuit in Figure 31 features a constant threshold voltage for turn on and turn off (zener voltage plus approximately one volt). If hysteresis is needed, the circuit in Figure 32 has a turn ON voltage which is different than the turn OFF voltage. The amount of hysteresis is approximately equal to the value of the output voltage. If zener voltages greater than 25V are used, an additional 47 kΩ resistor is needed from the ON /OFF pin to the ground pin to stay within the 25V maximum limit of the ON /OFF pin.

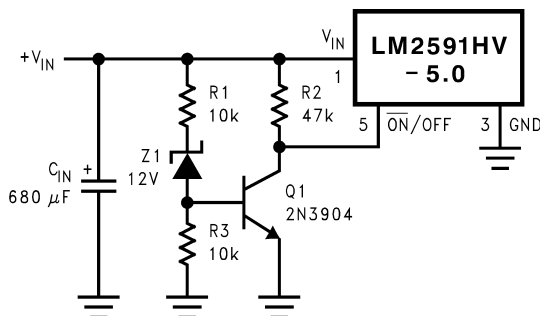
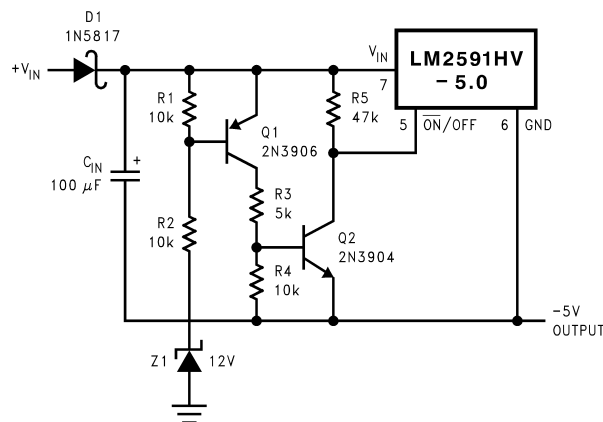

Figure 30. Undervoltage Lockout for Buck Regulator



This circuit has an ON/OFF threshold of approximately 13V.

Figure 31. Undervoltage Lockout for Inverting Regulator

(Adjustable Output Voltage Version)

INVERTING REGULATOR

The circuit in [Figure 33](#) converts a positive input voltage to a negative output voltage with a common ground. The circuit operates by bootstrapping the regulator's ground pin to the negative output voltage, then grounding the feedback pin, the regulator senses the inverted output voltage and regulates it.

This example uses the LM2591HV-5.0 to generate a -5V output, but other output voltages are possible by selecting other output voltage versions, including the adjustable version. Since this regulator topology can produce an output voltage that is either greater than or less than the input voltage, the maximum output current greatly depends on both the input and output voltage.

To determine how much load current is possible before the internal device current limit is reached (and power limiting occurs), the system must be evaluated as a buck-boost configuration rather than as a buck. The peak switch current in Amperes, for such a configuration is given as:

$$I_{PEAK} = I_{LOAD} \times \left(\frac{V_{IN} + V_{OUT}}{V_{IN}} \right) + \frac{V_{IN} \times V_{OUT} \times 10^6}{2 \times L \times f \times (V_{IN} + V_{OUT})}$$

where

- L is in μH
- and f is in Hz
- The maximum possible load current I_{LOAD} is limited by the requirement that $I_{PEAK} \leq I_{CLIM}$ (8)

While checking for this, take I_{CLIM} to be the lowest possible current limit value (min across tolerance and temperature is 1.2A for the LM2591HV). Also to account for inductor tolerances, we should take the min value of Inductance for L in [Equation 8](#) (typically 20% less than the nominal value). Further, [Equation 8](#) disregards the drop across the Switch and the diode. This is equivalent to assuming 100% efficiency, which is never so. Therefore expect I_{PEAK} to be an additional 10-20% higher than calculated from [Equation 8](#).

The reader is also referred to Application Note AN-1157 [SNVA022](#) for examples based on positive to negative configuration.

The maximum voltage appearing across the regulator is the absolute sum of the input and output voltage, and this must be limited to a maximum of 60V. For example, when converting +20V to -12V, the regulator would see 32V between the input pin and ground pin. The LM2591HV has a maximum input voltage spec of 60V.

Additional diodes are required in this regulator configuration. Diode D1 is used to isolate input voltage ripple or noise from coupling through the C_{IN} capacitor to the output, under light or no load conditions. Also, this diode isolation changes the topology to closely resemble a buck configuration thus providing good closed loop stability. A Schottky diode is recommended for low input voltages, (because of its lower voltage drop) but for higher input voltages, a fast recovery diode could be used.

Without diode D3, when the input voltage is first applied, the charging current of C_{IN} can pull the output positive by several volts for a short period of time. Adding D3 prevents the output from going positive by more than a diode voltage.

(Adjustable Output Voltage Version)

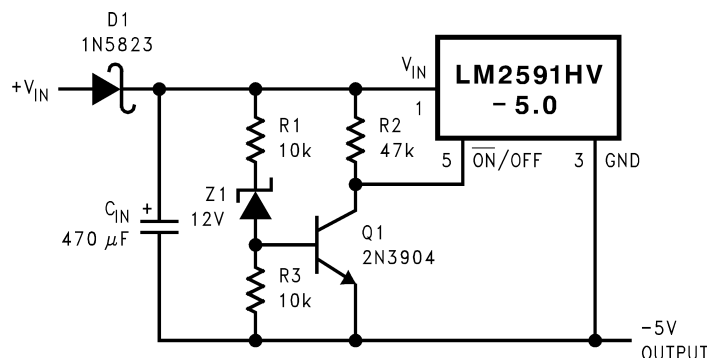

This circuit has hysteresis

Regulator starts switching at $V_{IN} = 13V$

Regulator stops switching at $V_{IN} = 8V$

Figure 32. Undervoltage Lockout with Hysteresis for Inverting Regulator

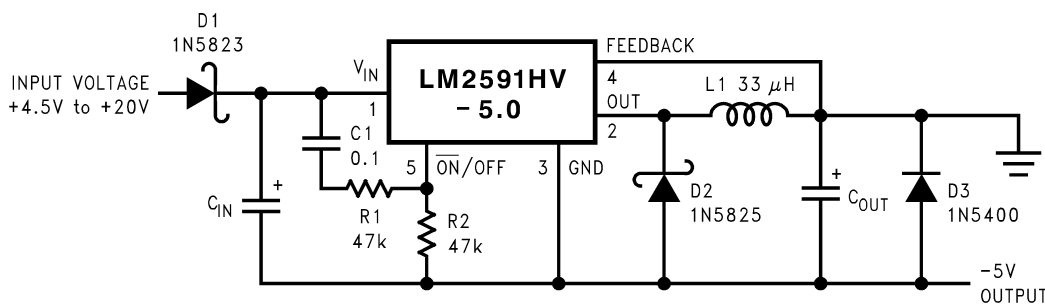

C_{IN} —68 $\mu F/25V$ Tant. Sprague 595D

470 $\mu F/50V$ Elec. Panasonic HFQ

C_{OUT} —47 $\mu F/20V$ Tant. Sprague 595D

220 $\mu F/25V$ Elec. Panasonic HFQ

Figure 33. Inverting -5V Regulator with Delayed Startup

Because of differences in the operation of the inverting regulator, the standard design procedure is not used to select the inductor value. In the majority of designs, a 33 μH , 3A inductor is the best choice. Capacitor selection can also be narrowed down to just a few values.

This type of inverting regulator can require relatively large amounts of input current when starting up, even with light loads. Input currents as high as the LM2591HV current limit (approx 4A) are needed for at least 2 ms or more, until the output reaches its nominal output voltage. The actual time depends on the output voltage and the size of the output capacitor. Input power sources that are current limited or sources that can not deliver these currents without getting loaded down, may not work correctly. Because of the relatively high startup currents required by the inverting topology, the delayed startup feature (C_1 , R_1 and R_2) shown in Figure 33 is recommended. By delaying the regulator startup, the input capacitor is allowed to charge up to a higher voltage before the switcher begins operating. A portion of the high input current needed for startup is now supplied by the input capacitor (C_{IN}). For severe start up conditions, the input capacitor can be made much larger than normal.

INVERTING REGULATOR SHUTDOWN METHODS

To use the \overline{ON}/OFF pin in a standard buck configuration is simple, pull it below 1.3V (@25°C, referenced to ground) to turn regulator ON, pull it above 1.3V to shut the regulator OFF. With the inverting configuration, some level shifting is required, because the ground pin of the regulator is no longer at ground, but is now setting at the negative output voltage level. Two different shutdown methods for inverting regulators are shown in Figure 34 and Figure 35.

(Adjustable Output Voltage Version)

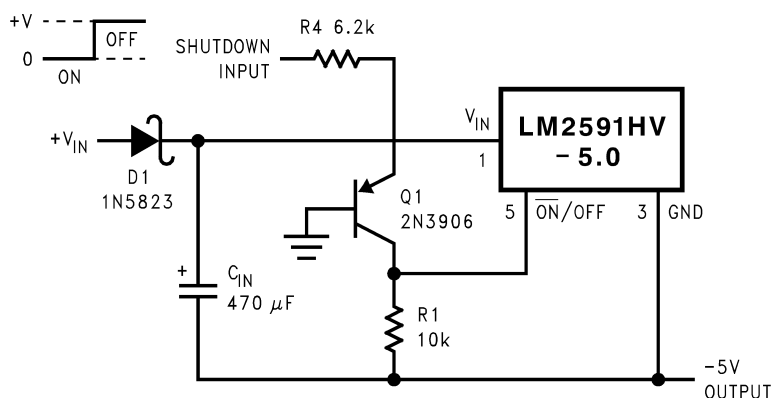

Figure 34. Inverting Regulator Ground Referenced Shutdown

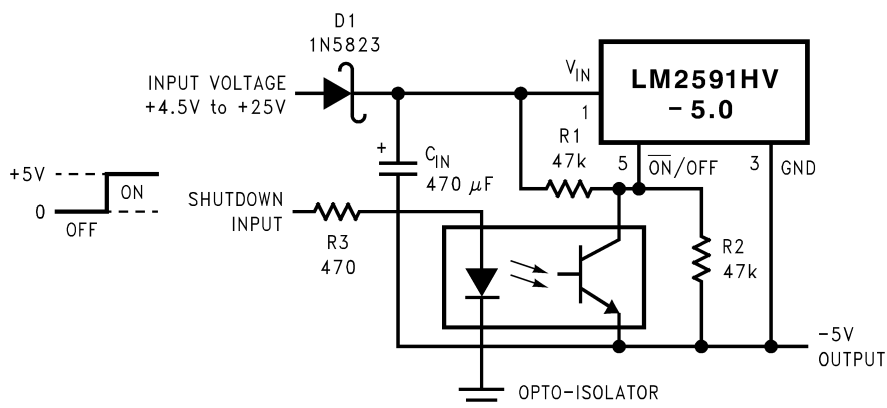

Figure 35. Inverting Regulator Ground Referenced Shutdown using Opto Device

LAYOUT SUGGESTIONS

As in any switching regulator, layout is very important. Rapidly switching currents associated with wiring inductance can generate voltage transients which can cause problems. For minimal inductance and ground loops, with reference to [Test Circuit and Layout Guidelines](#), the wires indicated by **heavy lines should be wide printed circuit traces and should be kept as short as possible**. For best results, external components should be located as close to the switcher IC as possible using ground plane construction or single point grounding.

If **open core inductors are used**, special care must be taken as to the location and positioning of this type of inductor. Allowing the inductor flux to intersect sensitive feedback, IC groundpath and C_{OUT} wiring can cause problems.

When using the adjustable version, special care must be taken as to the location of the feedback resistors and the associated wiring. Physically locate both resistors near the IC, and route the wiring away from the inductor, especially an open core type of inductor.

REVISION HISTORY

Changes from Revision C (April 2013) to Revision D	Page
• Changed layout of National Data Sheet to TI format	20

PACKAGING INFORMATION

Orderable Device	Status (1)	Package Type	Package Drawing	Pins	Package Qty	Eco Plan (2)	Lead/Ball Finish (6)	MSL Peak Temp (3)	Op Temp (°C)	Device Marking (4/5)	Samples
LM2591HVS-3.3/NOPB	ACTIVE	DDPAK/ TO-263	KTT	5	45	Pb-Free (RoHS Exempt)	CU SN	Level-3-245C-168 HR	-40 to 125	LM2591HVS -3.3 P+	Samples
LM2591HVS-5.0	NRND	DDPAK/ TO-263	KTT	5	45	TBD	Call TI	Call TI	-40 to 125	LM2591HVS -5.0 P+	
LM2591HVS-5.0/NOPB	ACTIVE	DDPAK/ TO-263	KTT	5	45	Pb-Free (RoHS Exempt)	CU SN	Level-3-245C-168 HR	-40 to 125	LM2591HVS -5.0 P+	Samples
LM2591HVS-ADJ	NRND	DDPAK/ TO-263	KTT	5	45	TBD	Call TI	Call TI	-40 to 125	LM2591HVS -ADJ P+	
LM2591HVS-ADJ/NOPB	ACTIVE	DDPAK/ TO-263	KTT	5	45	Pb-Free (RoHS Exempt)	CU SN	Level-3-245C-168 HR	-40 to 125	LM2591HVS -ADJ P+	Samples
LM2591HVSX-3.3/NOPB	ACTIVE	DDPAK/ TO-263	KTT	5	500	Pb-Free (RoHS Exempt)	CU SN	Level-3-245C-168 HR	-40 to 125	LM2591HVS -3.3 P+	Samples
LM2591HVSX-5.0	NRND	DDPAK/ TO-263	KTT	5	500	TBD	Call TI	Call TI	-40 to 125	LM2591HVS -5.0 P+	
LM2591HVSX-5.0/NOPB	ACTIVE	DDPAK/ TO-263	KTT	5	500	Pb-Free (RoHS Exempt)	CU SN	Level-3-245C-168 HR	-40 to 125	LM2591HVS -5.0 P+	Samples
LM2591HVSX-ADJ	NRND	DDPAK/ TO-263	KTT	5	500	TBD	Call TI	Call TI	-40 to 125	LM2591HVS -ADJ P+	
LM2591HVSX-ADJ/NOPB	ACTIVE	DDPAK/ TO-263	KTT	5	500	Pb-Free (RoHS Exempt)	CU SN	Level-3-245C-168 HR	-40 to 125	LM2591HVS -ADJ P+	Samples
LM2591HVT-3.3/NOPB	ACTIVE	TO-220	NDH	5	45	Green (RoHS & no Sb/Br)	CU SN	Level-1-NA-UNLIM	-40 to 125	LM2591HVT -3.3 P+	Samples
LM2591HVT-5.0	NRND	TO-220	NDH	5	45	TBD	Call TI	Call TI	-40 to 125	LM2591HVT -5.0 P+	
LM2591HVT-5.0/NOPB	ACTIVE	TO-220	NDH	5	45	Green (RoHS & no Sb/Br)	CU SN	Level-1-NA-UNLIM	-40 to 125	LM2591HVT -5.0 P+	Samples
LM2591HVT-ADJ/LF16	ACTIVE	TO-220	KC	5	45	Green (RoHS & no Sb/Br)	CU SN	Level-1-NA-UNLIM		LM2591HVT -ADJ P+	Samples
LM2591HVT-ADJ/NOPB	ACTIVE	TO-220	NDH	5	45	Green (RoHS & no Sb/Br)	CU SN	Level-1-NA-UNLIM	-40 to 125	LM2591HVT -ADJ P+	Samples

(1) The marketing status values are defined as follows:

ACTIVE: Product device recommended for new designs.

LIFEBUY: TI has announced that the device will be discontinued, and a lifetime-buy period is in effect.

NRND: Not recommended for new designs. Device is in production to support existing customers, but TI does not recommend using this part in a new design.

PREVIEW: Device has been announced but is not in production. Samples may or may not be available.

OBSOLETE: TI has discontinued the production of the device.

⁽²⁾ Eco Plan - The planned eco-friendly classification: Pb-Free (RoHS), Pb-Free (RoHS Exempt), or Green (RoHS & no Sb/Br) - please check <http://www.ti.com/productcontent> for the latest availability information and additional product content details.

TBD: The Pb-Free/Green conversion plan has not been defined.

Pb-Free (RoHS): TI's terms "Lead-Free" or "Pb-Free" mean semiconductor products that are compatible with the current RoHS requirements for all 6 substances, including the requirement that lead not exceed 0.1% by weight in homogeneous materials. Where designed to be soldered at high temperatures, TI Pb-Free products are suitable for use in specified lead-free processes.

Pb-Free (RoHS Exempt): This component has a RoHS exemption for either 1) lead-based flip-chip solder bumps used between the die and package, or 2) lead-based die adhesive used between the die and leadframe. The component is otherwise considered Pb-Free (RoHS compatible) as defined above.

Green (RoHS & no Sb/Br): TI defines "Green" to mean Pb-Free (RoHS compatible), and free of Bromine (Br) and Antimony (Sb) based flame retardants (Br or Sb do not exceed 0.1% by weight in homogeneous material)

⁽³⁾ MSL, Peak Temp. - The Moisture Sensitivity Level rating according to the JEDEC industry standard classifications, and peak solder temperature.

⁽⁴⁾ There may be additional marking, which relates to the logo, the lot trace code information, or the environmental category on the device.

⁽⁵⁾ Multiple Device Markings will be inside parentheses. Only one Device Marking contained in parentheses and separated by a "~" will appear on a device. If a line is indented then it is a continuation of the previous line and the two combined represent the entire Device Marking for that device.

⁽⁶⁾ Lead/Ball Finish - Orderable Devices may have multiple material finish options. Finish options are separated by a vertical ruled line. Lead/Ball Finish values may wrap to two lines if the finish value exceeds the maximum column width.

Important Information and Disclaimer: The information provided on this page represents TI's knowledge and belief as of the date that it is provided. TI bases its knowledge and belief on information provided by third parties, and makes no representation or warranty as to the accuracy of such information. Efforts are underway to better integrate information from third parties. TI has taken and continues to take reasonable steps to provide representative and accurate information but may not have conducted destructive testing or chemical analysis on incoming materials and chemicals. TI and TI suppliers consider certain information to be proprietary, and thus CAS numbers and other limited information may not be available for release.

In no event shall TI's liability arising out of such information exceed the total purchase price of the TI part(s) at issue in this document sold by TI to Customer on an annual basis.

TAPE AND REEL INFORMATION

QUADRANT ASSIGNMENTS FOR PIN 1 ORIENTATION IN TAPE

*All dimensions are nominal

Device	Package Type	Package Drawing	Pins	SPQ	Reel Diameter (mm)	Reel Width W1 (mm)	A0 (mm)	B0 (mm)	K0 (mm)	P1 (mm)	W (mm)	Pin1 Quadrant
LM2591HVSX-3.3/NOPB	DDPAK/TO-263	KTT	5	500	330.0	24.4	10.75	14.85	5.0	16.0	24.0	Q2
LM2591HVSX-5.0	DDPAK/TO-263	KTT	5	500	330.0	24.4	10.75	14.85	5.0	16.0	24.0	Q2
LM2591HVSX-5.0/NOPB	DDPAK/TO-263	KTT	5	500	330.0	24.4	10.75	14.85	5.0	16.0	24.0	Q2
LM2591HVSX-ADJ	DDPAK/TO-263	KTT	5	500	330.0	24.4	10.75	14.85	5.0	16.0	24.0	Q2
LM2591HVSX-ADJ/NOPB	DDPAK/TO-263	KTT	5	500	330.0	24.4	10.75	14.85	5.0	16.0	24.0	Q2

TAPE AND REEL BOX DIMENSIONS

*All dimensions are nominal

Device	Package Type	Package Drawing	Pins	SPQ	Length (mm)	Width (mm)	Height (mm)
LM2591HVSX-3.3/NOPB	DDPAK/TO-263	KTT	5	500	367.0	367.0	45.0
LM2591HVSX-5.0	DDPAK/TO-263	KTT	5	500	367.0	367.0	45.0
LM2591HVSX-5.0/NOPB	DDPAK/TO-263	KTT	5	500	367.0	367.0	45.0
LM2591HVSX-ADJ	DDPAK/TO-263	KTT	5	500	367.0	367.0	45.0
LM2591HVSX-ADJ/NOPB	DDPAK/TO-263	KTT	5	500	367.0	367.0	45.0

NDH0005D

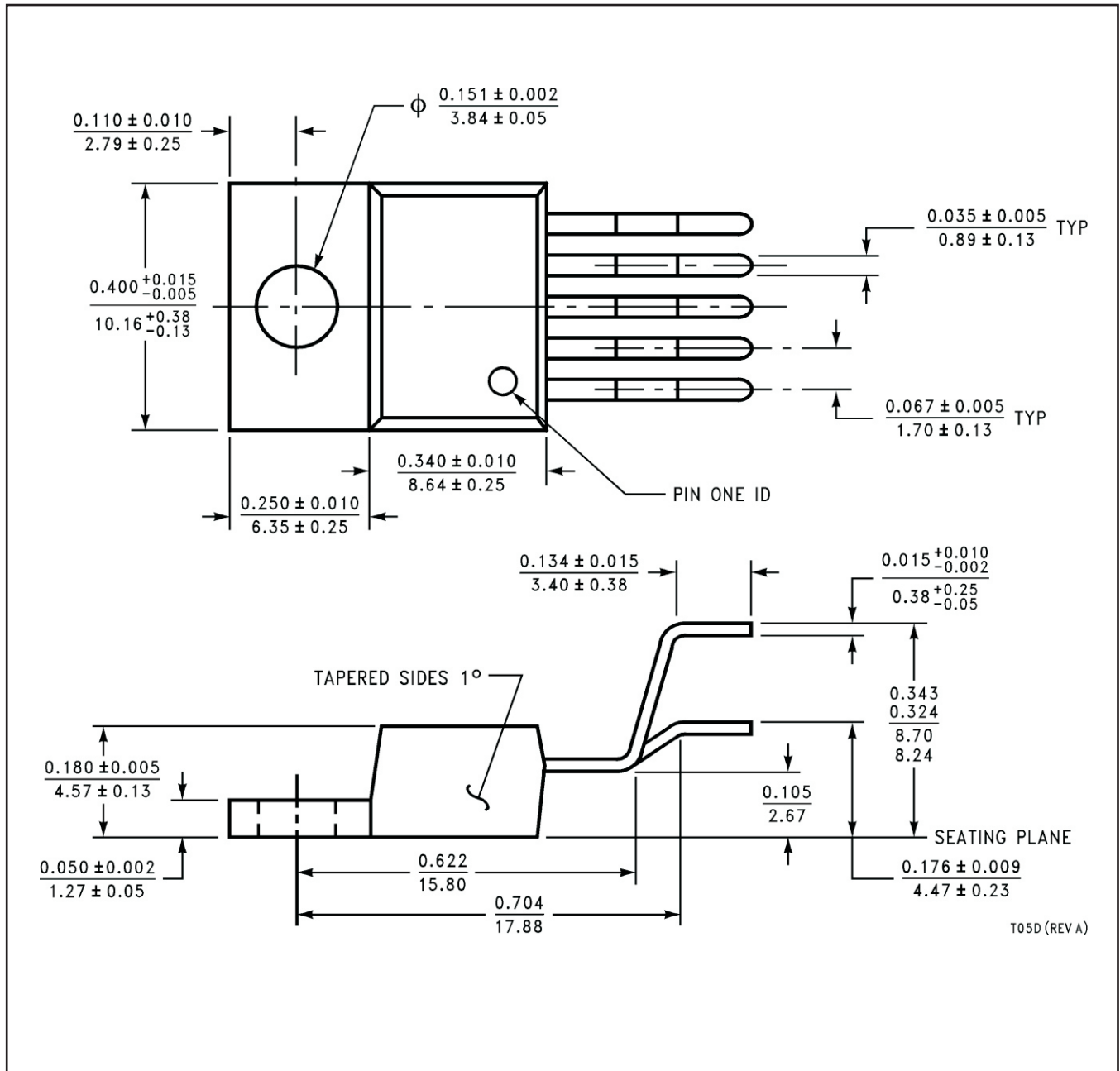

T05D (REV A)

KTT0005B

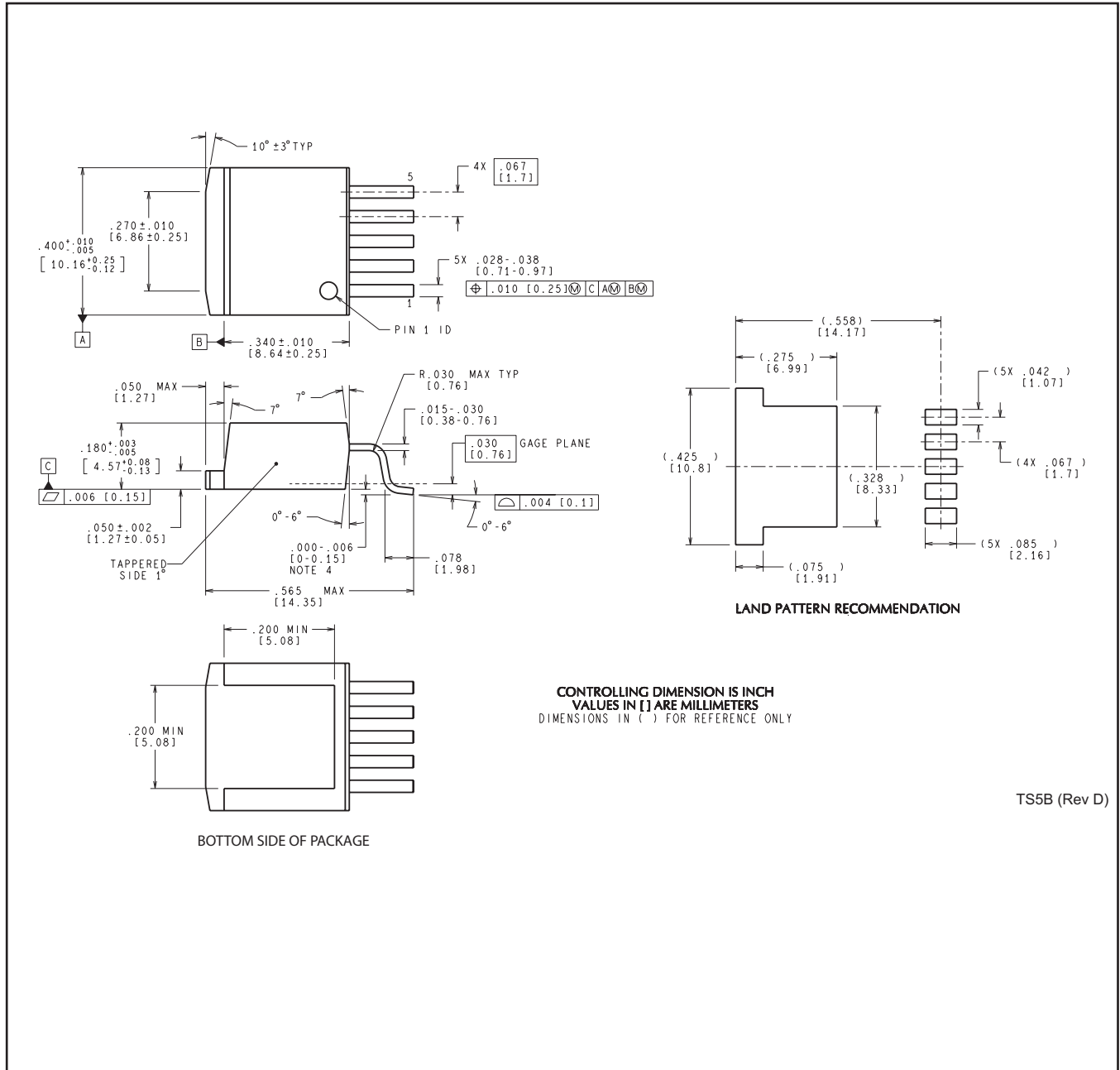



CONTROLLING DIMENSION IS INCH
 VALUES IN [] ARE MILLIMETERS
 DIMENSIONS IN () FOR REFERENCE ONLY

TS5B (Rev D)

KC (R-PSFM-T5)

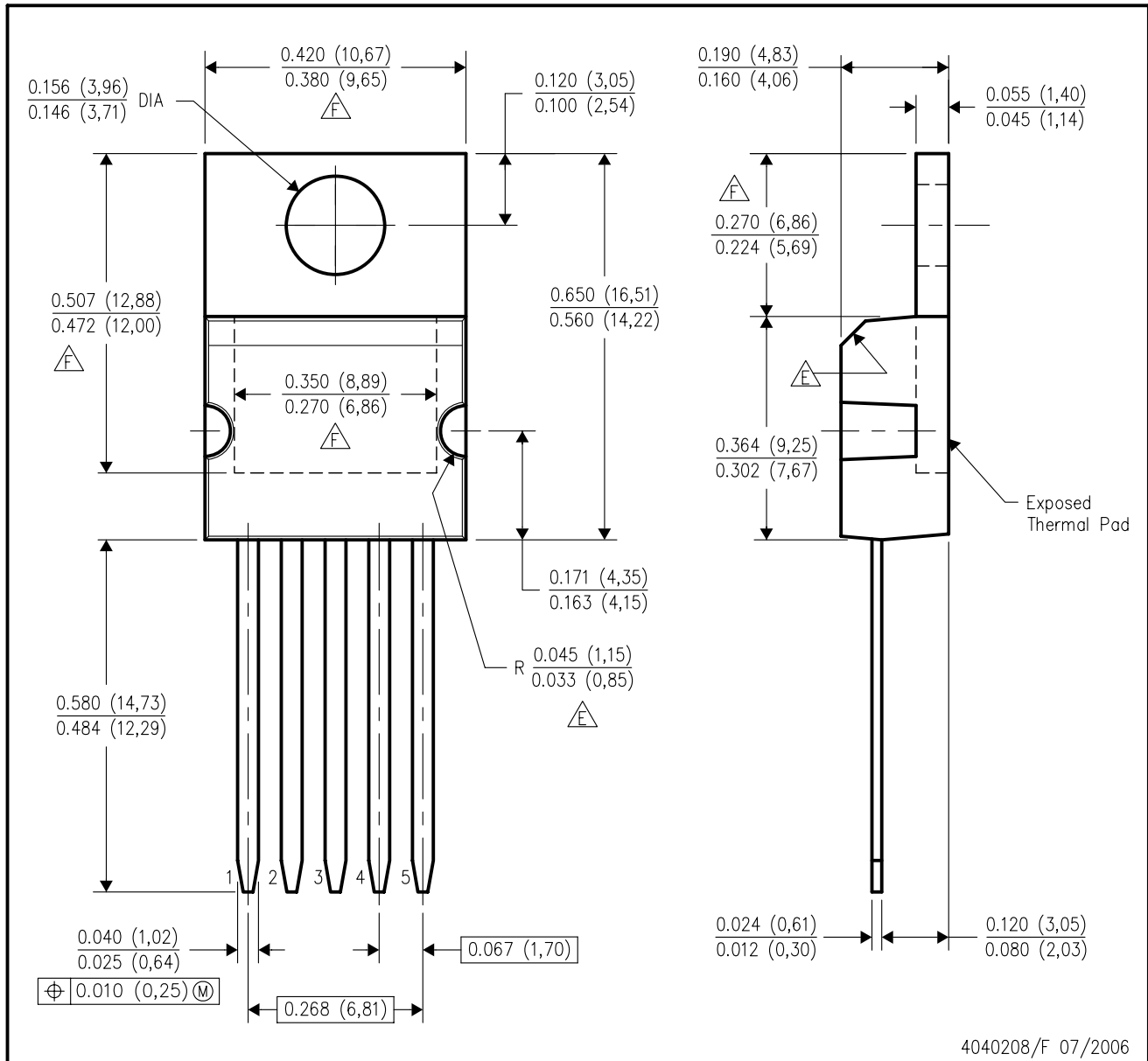
PLASTIC FLANGE-MOUNT PACKAGE



- NOTES:
- A. All linear dimensions are in inches (millimeters).
 - B. This drawing is subject to change without notice.
 - C. All lead dimensions apply before solder dip.
 - D. The center lead is in electrical contact with the mounting tab.
 -  These features are optional.
 -  Thermal pad contour optional within these dimensions.

IMPORTANT NOTICE

Texas Instruments Incorporated and its subsidiaries (TI) reserve the right to make corrections, enhancements, improvements and other changes to its semiconductor products and services per JESD46, latest issue, and to discontinue any product or service per JESD48, latest issue. Buyers should obtain the latest relevant information before placing orders and should verify that such information is current and complete. All semiconductor products (also referred to herein as "components") are sold subject to TI's terms and conditions of sale supplied at the time of order acknowledgment.

TI warrants performance of its components to the specifications applicable at the time of sale, in accordance with the warranty in TI's terms and conditions of sale of semiconductor products. Testing and other quality control techniques are used to the extent TI deems necessary to support this warranty. Except where mandated by applicable law, testing of all parameters of each component is not necessarily performed.

TI assumes no liability for applications assistance or the design of Buyers' products. Buyers are responsible for their products and applications using TI components. To minimize the risks associated with Buyers' products and applications, Buyers should provide adequate design and operating safeguards.

TI does not warrant or represent that any license, either express or implied, is granted under any patent right, copyright, mask work right, or other intellectual property right relating to any combination, machine, or process in which TI components or services are used. Information published by TI regarding third-party products or services does not constitute a license to use such products or services or a warranty or endorsement thereof. Use of such information may require a license from a third party under the patents or other intellectual property of the third party, or a license from TI under the patents or other intellectual property of TI.

Reproduction of significant portions of TI information in TI data books or data sheets is permissible only if reproduction is without alteration and is accompanied by all associated warranties, conditions, limitations, and notices. TI is not responsible or liable for such altered documentation. Information of third parties may be subject to additional restrictions.

Resale of TI components or services with statements different from or beyond the parameters stated by TI for that component or service voids all express and any implied warranties for the associated TI component or service and is an unfair and deceptive business practice. TI is not responsible or liable for any such statements.

Buyer acknowledges and agrees that it is solely responsible for compliance with all legal, regulatory and safety-related requirements concerning its products, and any use of TI components in its applications, notwithstanding any applications-related information or support that may be provided by TI. Buyer represents and agrees that it has all the necessary expertise to create and implement safeguards which anticipate dangerous consequences of failures, monitor failures and their consequences, lessen the likelihood of failures that might cause harm and take appropriate remedial actions. Buyer will fully indemnify TI and its representatives against any damages arising out of the use of any TI components in safety-critical applications.

In some cases, TI components may be promoted specifically to facilitate safety-related applications. With such components, TI's goal is to help enable customers to design and create their own end-product solutions that meet applicable functional safety standards and requirements. Nonetheless, such components are subject to these terms.

No TI components are authorized for use in FDA Class III (or similar life-critical medical equipment) unless authorized officers of the parties have executed a special agreement specifically governing such use.

Only those TI components which TI has specifically designated as military grade or "enhanced plastic" are designed and intended for use in military/aerospace applications or environments. Buyer acknowledges and agrees that any military or aerospace use of TI components which have **not** been so designated is solely at the Buyer's risk, and that Buyer is solely responsible for compliance with all legal and regulatory requirements in connection with such use.

TI has specifically designated certain components as meeting ISO/TS16949 requirements, mainly for automotive use. In any case of use of non-designated products, TI will not be responsible for any failure to meet ISO/TS16949.

Products

Audio	www.ti.com/audio
Amplifiers	amplifier.ti.com
Data Converters	dataconverter.ti.com
DLP® Products	www.dlp.com
DSP	dsp.ti.com
Clocks and Timers	www.ti.com/clocks
Interface	interface.ti.com
Logic	logic.ti.com
Power Mgmt	power.ti.com
Microcontrollers	microcontroller.ti.com
RFID	www.ti-rfid.com
OMAP Applications Processors	www.ti.com/omap
Wireless Connectivity	www.ti.com/wirelessconnectivity

Applications

Automotive and Transportation	www.ti.com/automotive
Communications and Telecom	www.ti.com/communications
Computers and Peripherals	www.ti.com/computers
Consumer Electronics	www.ti.com/consumer-apps
Energy and Lighting	www.ti.com/energy
Industrial	www.ti.com/industrial
Medical	www.ti.com/medical
Security	www.ti.com/security
Space, Avionics and Defense	www.ti.com/space-avionics-defense
Video and Imaging	www.ti.com/video

TI E2E Community

e2e.ti.com



element14

EN - For pricing and availability in your local country please visit one of the below links:

DE - Informationen zu Preisen und Verfügbarkeit in Ihrem Land erhalten Sie über die unten aufgeführten Links:

FR - Pour connaître les tarifs et la disponibilité dans votre pays, cliquez sur l'un des liens suivants:

[LM2591HVS-3.3/NOPB](#)

[LM2591HVT-ADJ/NOPB](#)

EN

This Datasheet is presented by
the manufacturer

DE

Dieses Datenblatt wird vom
Hersteller bereitgestellt

FR

Cette fiche technique est
présentée par le fabricant